

Color Filter Wheel

CFW9-5

Rugged Design Unmatched Precision Flexible Performance

Our color filter wheel's robust mechanical design provides the basis for stunning, uncompromising images. Each FLI color filter wheel is precision engineered with a highly accurate no-slip drive chain and stepper motor. The large diameter pivot pin and bushings are precision ground and matched for smooth, quiet no-fuss operation night after night. FLI color filter wheels do not use internal lights for homing, so your images are protected from stray light interference.

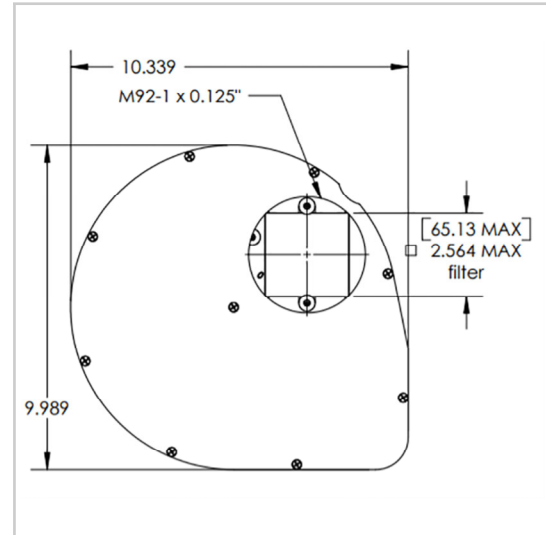

Technical Data

Filter Positions	5
Recommended Filter Size (+/- 0.125 mm)	65mm Square
Filter Thickness Range	1 to 5 mm
Wheels	1
Overall Thickness (less motor)	0.595" (15.11 mm)
Weight	3.2 lbs. (1.45 kg)
Interface	USB
Camera Side Connection	10-32 Bolt Pattern
Optical Side Connection	M92-1 thread
Wheel Material	Aluminum
Power	12V
Drawing URL	www.flicamera.com/drawings/CFW9-5.pdf