

REV	DESCRIPTION	DATE
A	Add ccd to flange top dist.	2/26/2008

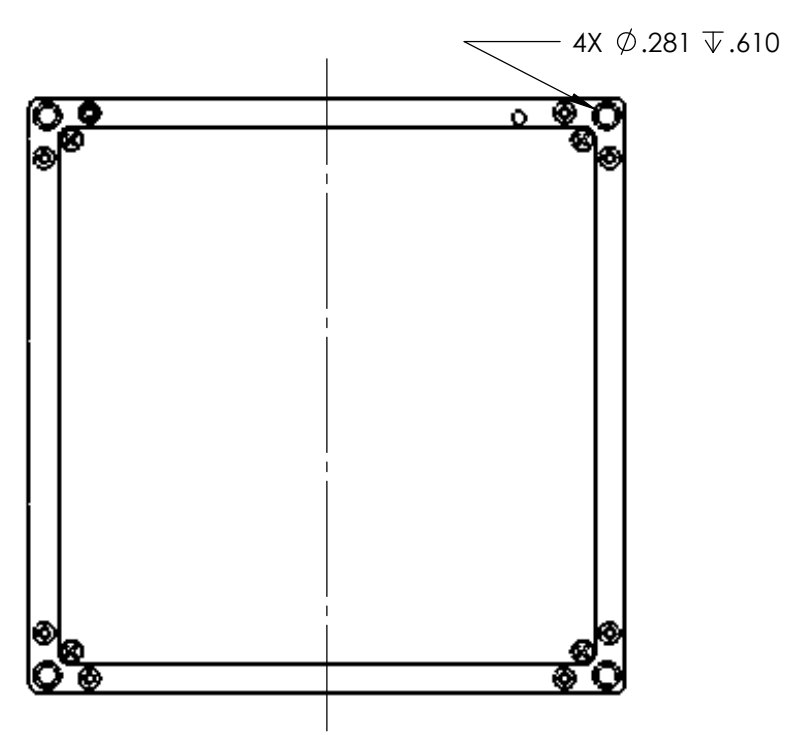
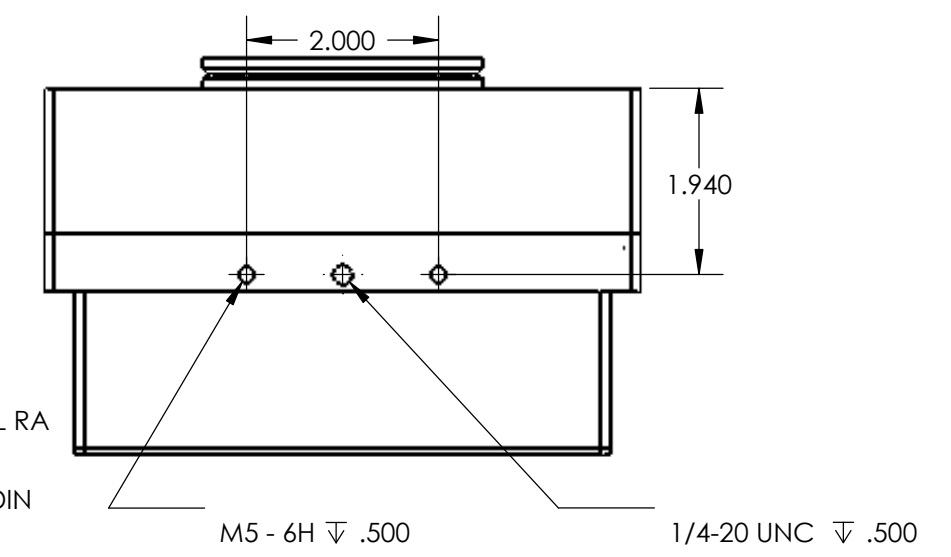
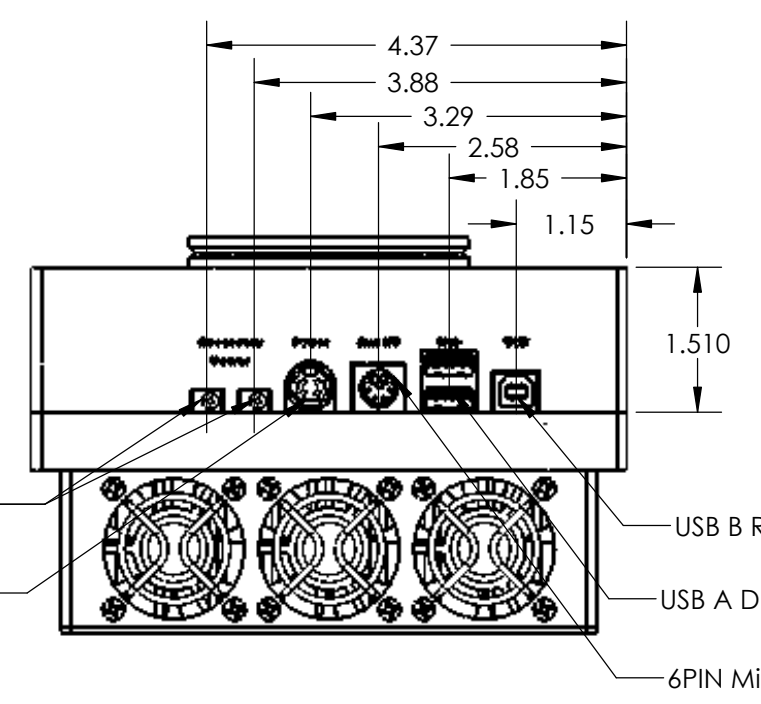
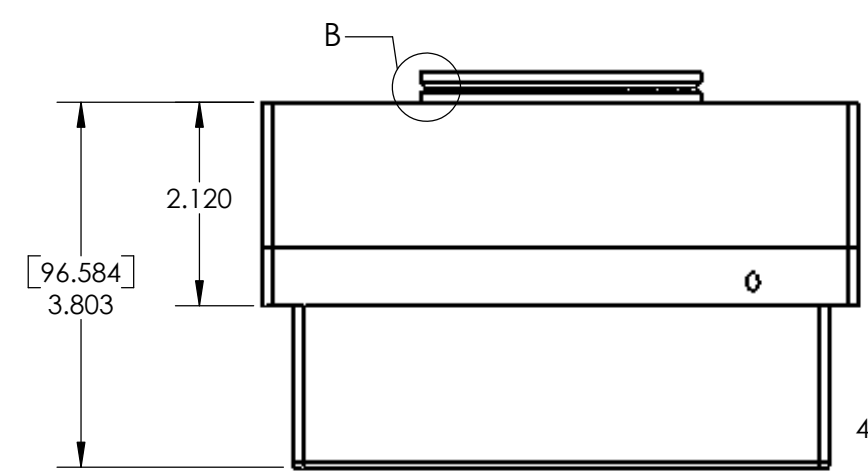
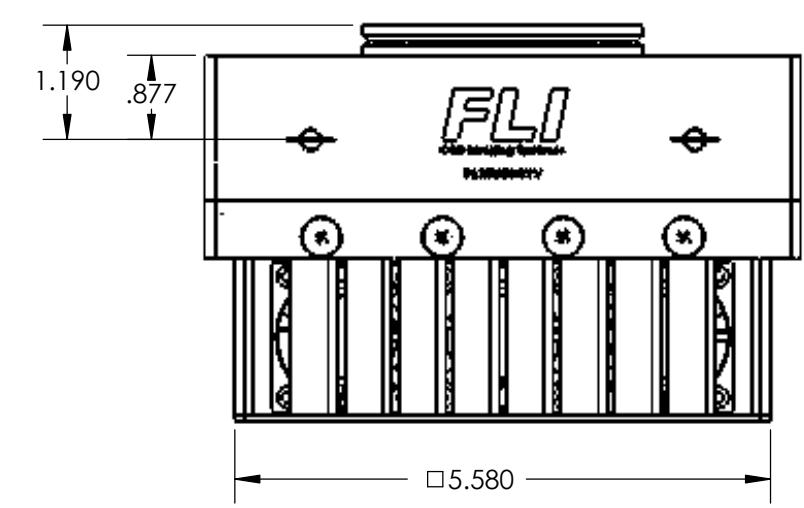
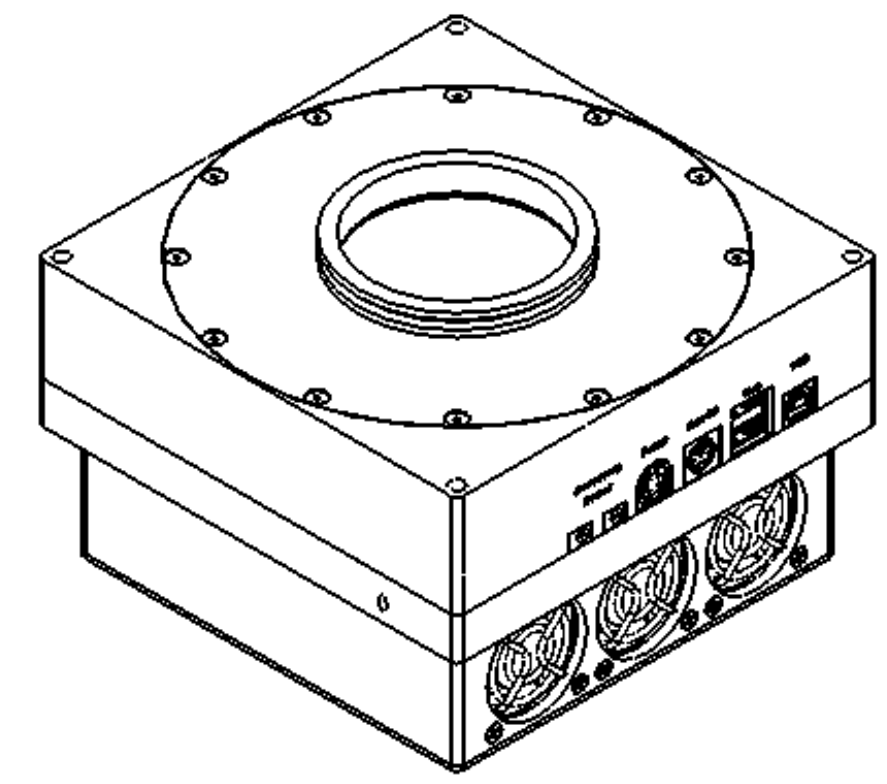
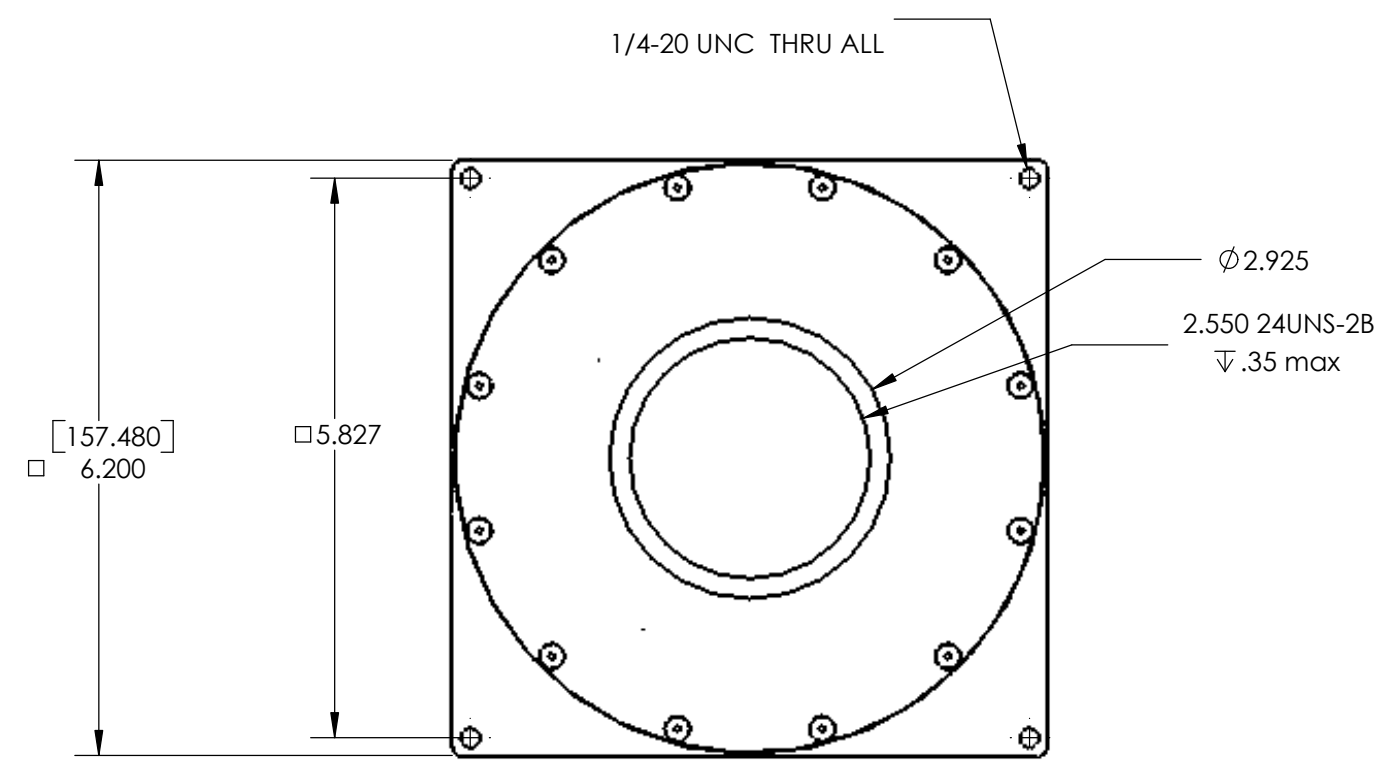
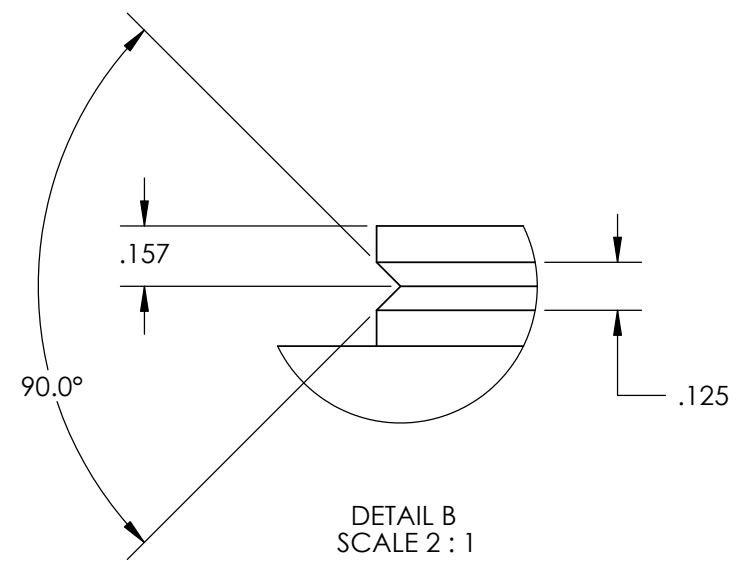

PROPRIETARY AND CONFIDENTIAL
THE INFORMATION CONTAINED IN THIS DRAWING IS THE SOLE PROPERTY OF ANY REPRODUCTION IN PART OR AS A WHOLE WITHOUT THE WRITTEN PERMISSION OF IS PROHIBITED.

UNLESS OTHERWISE SPECIFIED:		NAME	DATE
DIMENSIONS ARE IN INCHES		DRAWN	REC 04/18/06
TOLERANCES:		CHECKED	
ANGULAR: ±1°		ENG APPR.	
TWO PLACE DECIMAL ±.01		MFG APPR.	
THREE PLACE DECIMAL ±.003		Q.A.	
FOUR PLACE DECIMAL ±.0005		COMMENTS:	
INTERPRET GEOMETRIC TOLERANCING PER:			
MATERIAL:			
FINISH:			
NEXT ASSY	USED ON		
APPLICATION			
DO NOT SCALE DRAWING			

PL(X) 65MM		
where (x) = sensor pn		
TITLE: Camera Assy PROLINE		
SIZE C	DWG. NO. ASSY_PL(X)_65MM_AC	REV A
SCALE: 1:2	WEIGHT:	SHEET 1 OF 1