

MicroLine CCD Camera

ML4710 C-Mount

The back-illuminated CCD in the ML4710 has exceptionally high quantum efficiency. Larger pixels provide deep dynamic range and gather more light for improved signal-to-noise. Available with midband, broadband, or UV coating on the sensor.

Technical Data

Sensor Type	Back Illuminated CCD
Sensor	e2v CCD47-10
Active Pixels	1024 x 1024
Pixel Size (microns)	13 x 13 μm
Imaging Area (Diagonal)	13.3 X 13.3 mm (18.8 mm)
Full Well Capacity	100000 electrons
(e-) Typical_Readout Noise	10e- @ 700 kHz; 17e- @ 2 MHz
Typical Gain	1.3e-/ADU
Dynamic Range	79.7 dB
Anti-Blooming	None
Cooling Method	Air (Optional liquid)
Max. Cooling (Air)	60°C below ambient
Temperature Stability	0.1°C
Dark Current (typical)	0.1 eps at -40C
Interface	USB 2.0
Digitization Clock	700 kHz and 2 MHz digitization
Data Bit Depth	16 bit
Non-Linearity	<1%
Channels	1
Shutter	25mm
Lens Mount	C-mount; Optional Nikon
Subarray Readout	Standard
External Trigger In/Out	Standard
SDK / Software	USB2 / FLIGrab
Weight	2.8 lbs (1.2 kg)
Environment	-30°C to 45°C 10% - 90% Relative Humidity
Power	12V (100-240V AC to 12V DC power supply included). With TEC off: <1A. TEC at 100%: 4.4A. Shutter open: 4A pulse for 100msec. Shutter held open, add 0.22A.



Absolute Quantum Efficiency

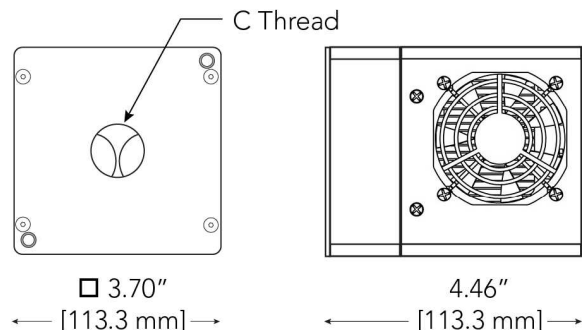
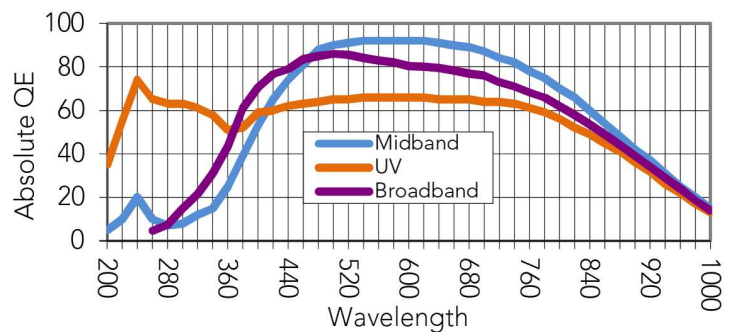

See www.flicamera.com for alternate configurations



MADE IN USA

Finger Lakes Instrumentation
www.flicamera.com
USA 585-624-3760