

# Kepler CMOS Camera

## KL4040 FI 65mm

### 4K x 4K at 23 fps

The KL4040 scientific CMOS camera has the same pixel size and imaging area as the popular KAF-16803 CCD, but with 1/3 the noise and 40% higher quantum efficiency. Kepler cooled sCMOS cameras provide ultra-high sensitivity, ultra-low noise, and high frame rates, all at game-changing price to performance ratio.

### Technical Data

<b>Sensor Type</b>	Front Illuminated CMOS
<b>Sensor</b>	GPixel GSense4040
<b>Shutter Type</b>	Rolling; Rolling with Global Reset
<b>Active Pixels</b>	4096 x 4096
<b>Pixel Size (microns)</b>	9 x 9 $\mu\text{m}$
<b>Imaging Area (Diagonal)</b>	36.8 X 36.8 mm (52 mm)
<b>Full Well Capacity</b>	70000 electrons
<b>(e-) Typical Readout Noise</b>	3.7 e-
<b>Dynamic Range</b>	85.2 dB
<b>Frame Rate</b>	23 fps (QSFP V2)
<b>Cooling Method<sup>1</sup></b>	Air and Liquid
<b>Max. Cooling (Air)</b>	40°C below ambient
<b>Temperature Stability</b>	0.1°C
<b>Dark Current (typical)</b>	0.08 eps at -10C
<b>Interface</b>	USB 3.0 (Optional QSFP <sup>2</sup> )
<b>Data Bit Depth</b>	16 bit <sup>3</sup>
<b>Optional Shutter</b>	65mm
<b>Optional Mounts</b>	Medium Format Recommended (6x7)
<b>Subarray Readout</b>	Standard
<b>External Trigger In/Out</b>	Standard
<b>SDK / Software</b>	Kepler SDK / FLI Pilot
<b>Weight</b>	4 lbs (1.8 kg)

<sup>1</sup> Liquid circulation connectors sold separately

<sup>2</sup> QSFP = Quad Small Form factor Pluggable: high speed fiber optic interface

<sup>3</sup> 16-bit data merged from two 12 bit converters



Shown with optional 65mm shutter housing

### Absolute Quantum Efficiency

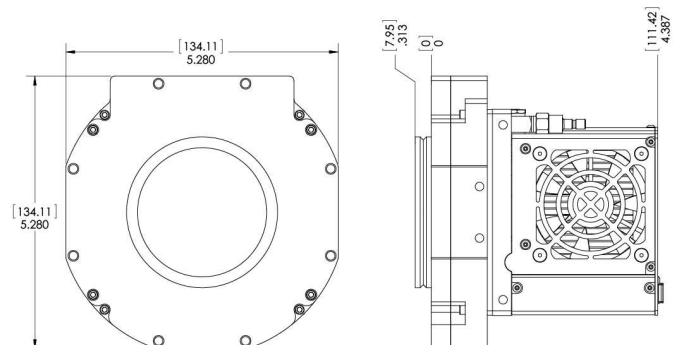
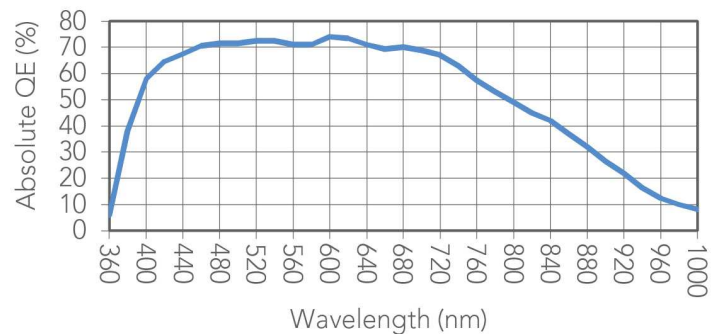

See [www.flicamera.com](http://www.flicamera.com) for alternate configurations



MADE IN USA

Finger Lakes Instrumentation  
[www.flicamera.com](http://www.flicamera.com)  
USA 585-624-3760