

REV.	DESCRIPTION	DATE
A	Release	12/1/12
B	Increase flange thickness	3/31/2017

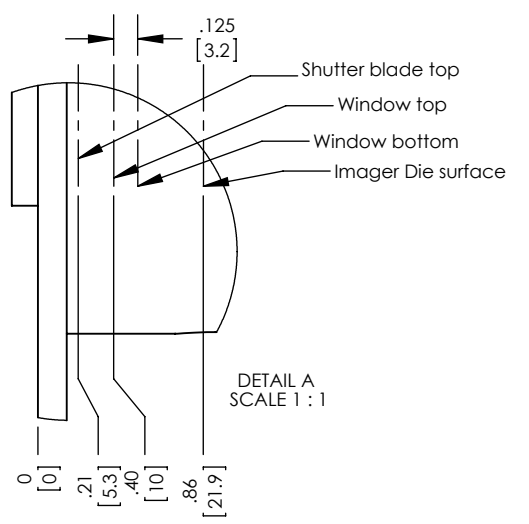
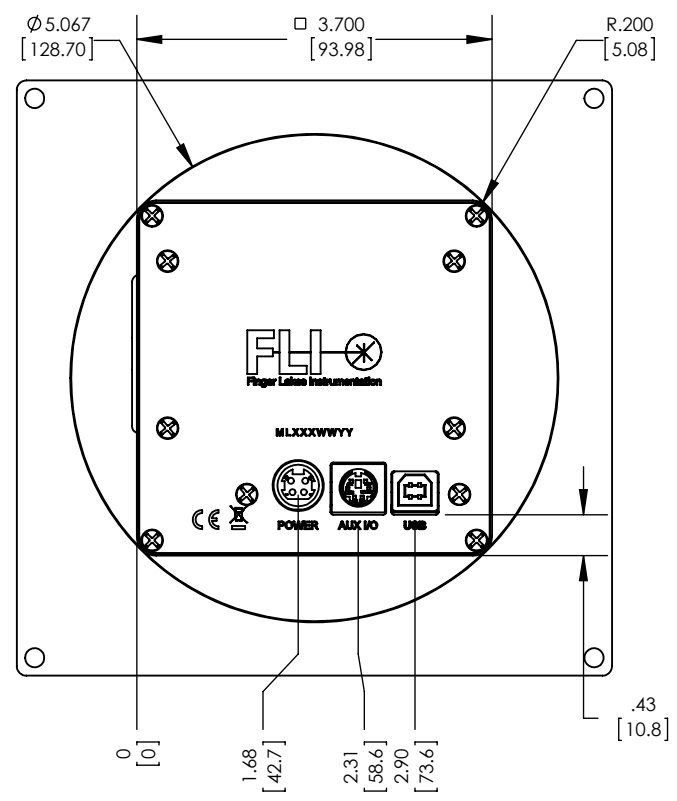
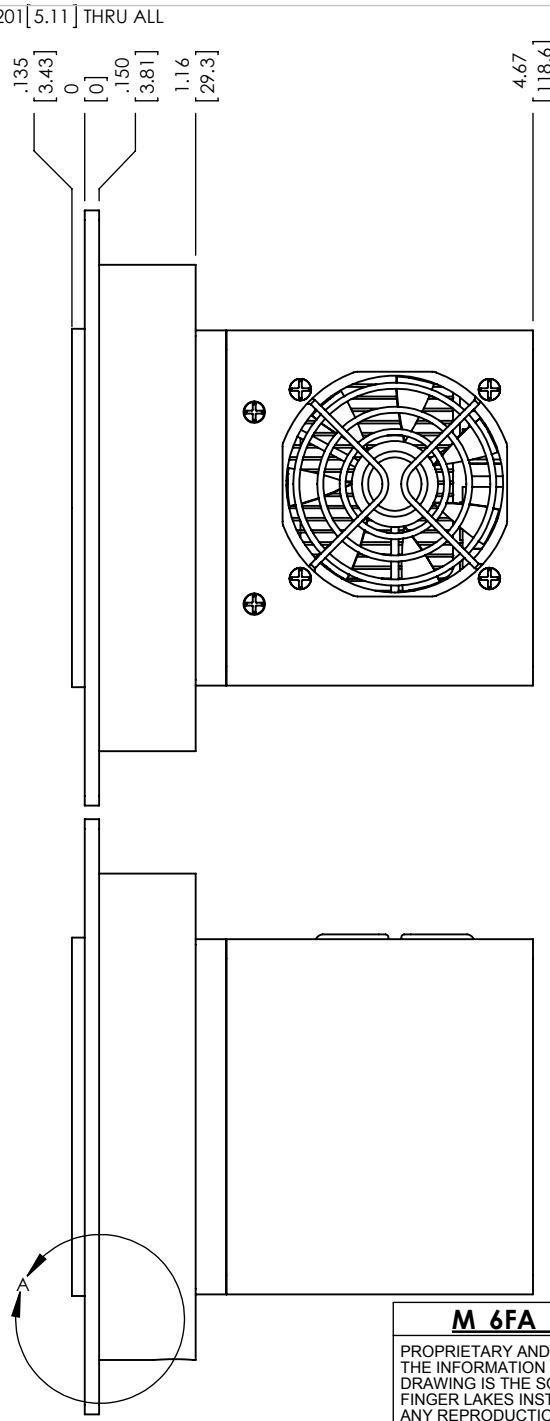
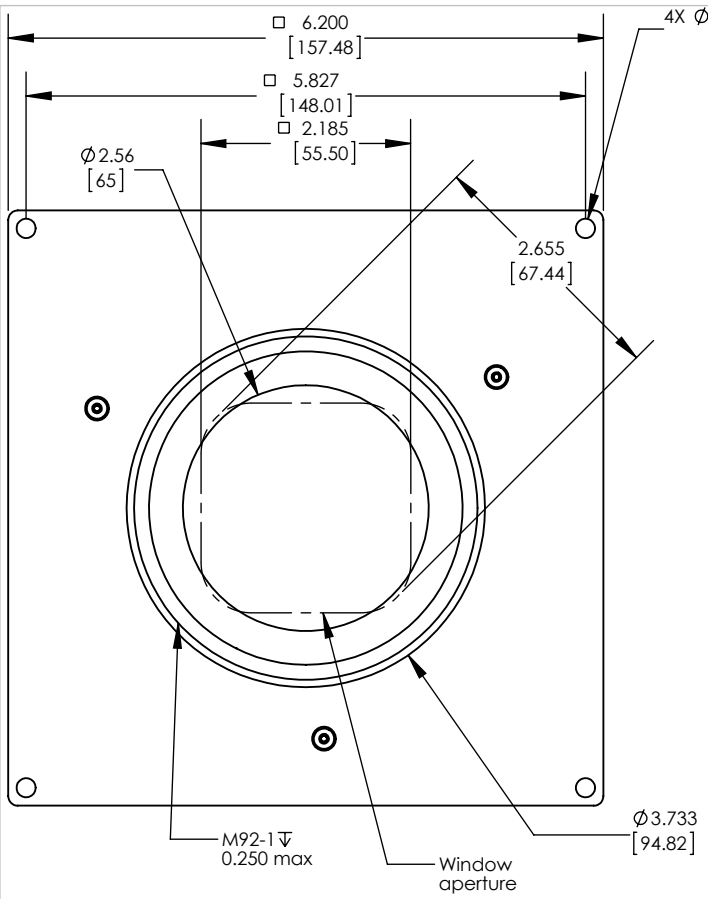

NOTES:
 1. All dimensions are physical.
 A. For optical distances:
 1. Subtract 1mm for sealing window.
 2. Subtract 0.3mm for CCD cover slip if present
 2. Unless otherwise noted all dimensions are symmetrical about centerline.

M 6FA		NAME	DATE	Unless otherwise specified dimensions are in inches	SIZE
PROPRIETARY AND CONFIDENTIAL: THE INFORMATION CONTAINED IN THIS DRAWING IS THE SOLE PROPERTY OF FINGER LAKES INSTRUMENTATION. ANY REPRODUCTION IN PART OR AS A WHOLE WITHOUT THE WRITTEN PERMISSION OF FINGER LAKES INSTRUMENTATION IS PROHIBITED.	DRAWN	REC	08/11/15	TOLERANCES: \angle : $\pm 1^\circ$ X.XX $\pm .01$ X.XXX $\pm .003$ X.XXXX $\pm .0005$	A
	ENG.				WT:
	QUALITY				REV
	PROD.			INTERPRET GEOMETRIC TOLERANCING PER: ASME Y14.5	A
	DO NOT SCALE DRAWING				SCALE: 1:2
					SHEET 1 OF 1