

REV.	DESCRIPTION	DATE
A	Move engraving & purge port, add mount holes, reduce back focus	1/15/2010
B	Remove flange screw, add WEE symbol, new logo & focal plane	10/10/2012

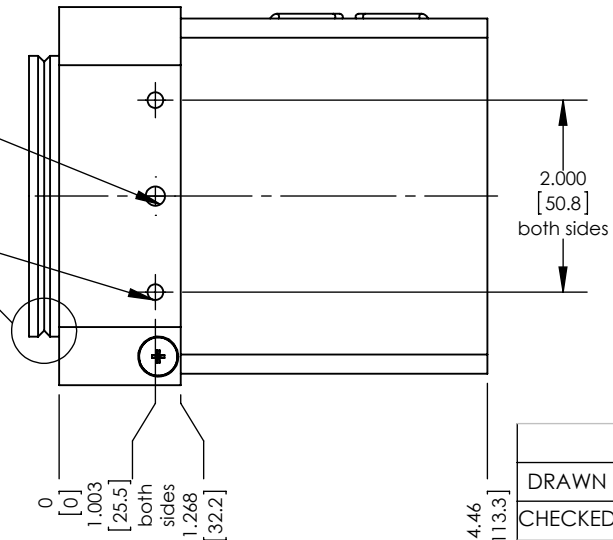
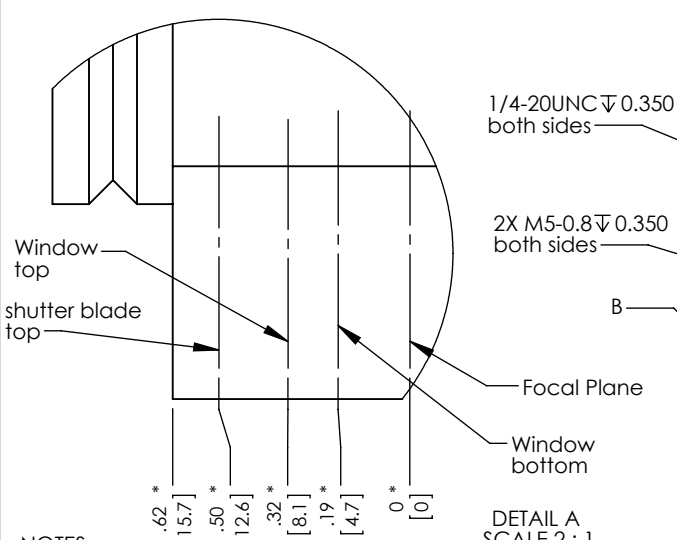
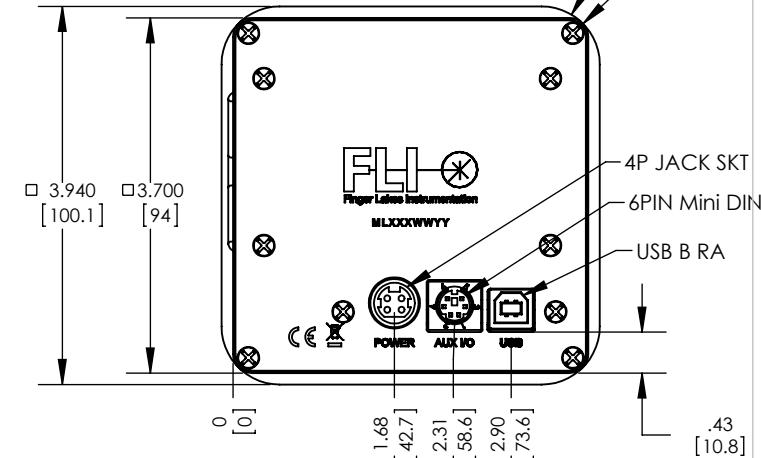
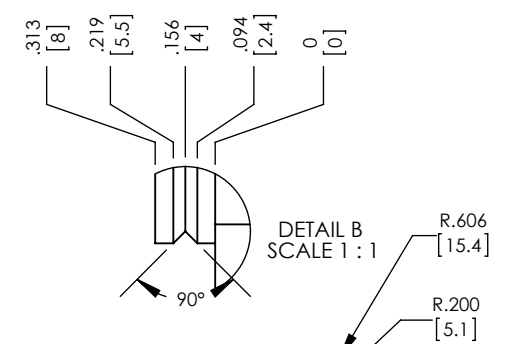
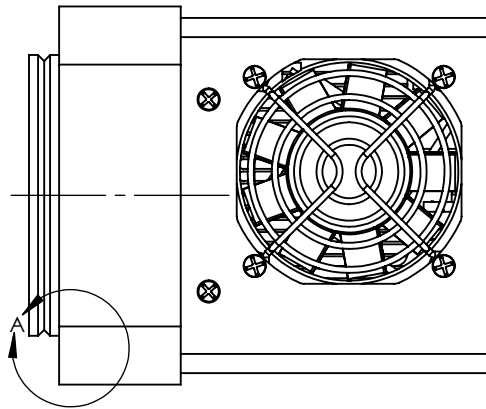
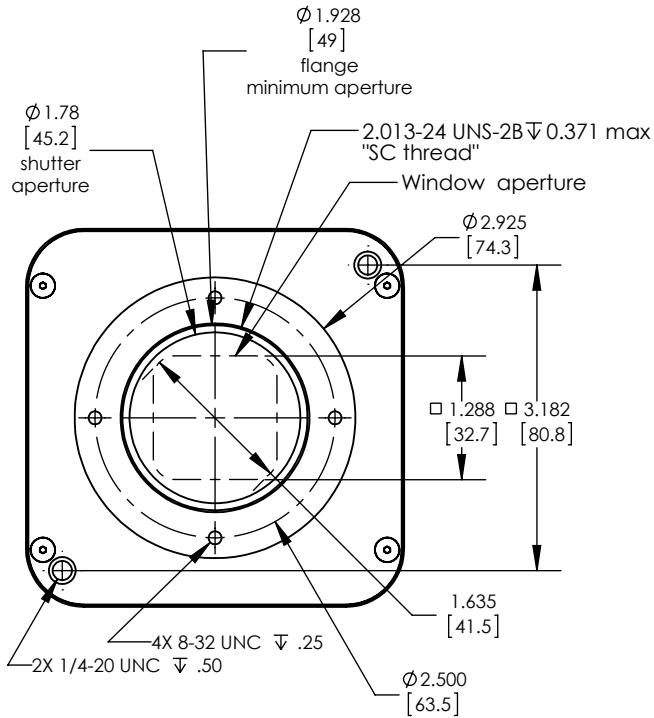

ML_45mm_AC

PROPRIETARY AND CONFIDENTIAL: THE INFORMATION CONTAINED IN THIS DRAWING IS THE SOLE PROPERTY OF FINGER LAKES INSTRUMENTATION. ANY REPRODUCTION IN PART OR AS A WHOLE WITHOUT THE WRITTEN PERMISSION OF FINGER LAKES INSTRUMENTATION IS PROHIBITED.

NOTES:
1.* - Optical distance

	NAME	DATE	SIZE	A	REV	B
DRAWN	REC	4/18/11	MATERIAL:	UNLESS OTHERWISE SPECIFIED: DIMENSIONS ARE IN INCHES TOLERANCES: ANGULAR: $\pm 1^\circ$ TWO PLACE DECIMAL $\pm .01$ THREE PLACE DECIMAL $\pm .003$ FOUR PLACE DECIMAL $\pm .0005$		FINISH:
CHECKED						
DO NOT SCALE DRAWING			SCALE: 1:2	WEIGHT:	SHEET 1 OF 1	