

REV.	DESCRIPTION	DATE
A	RELEASE	04/29/16

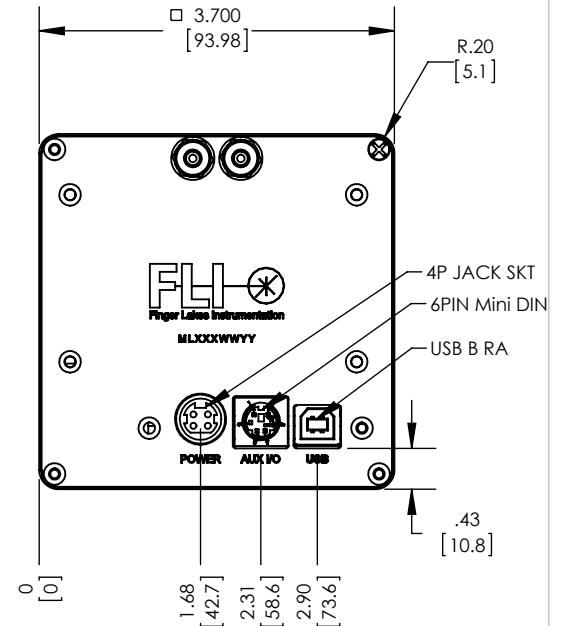
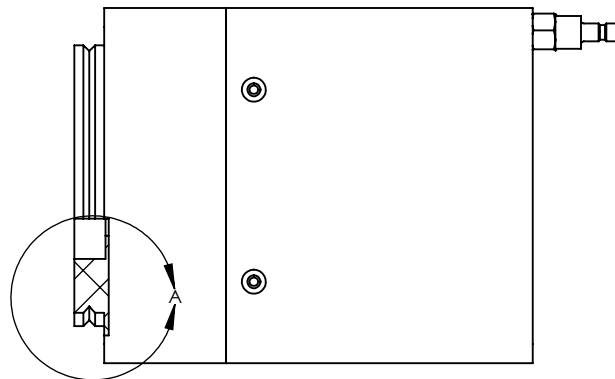
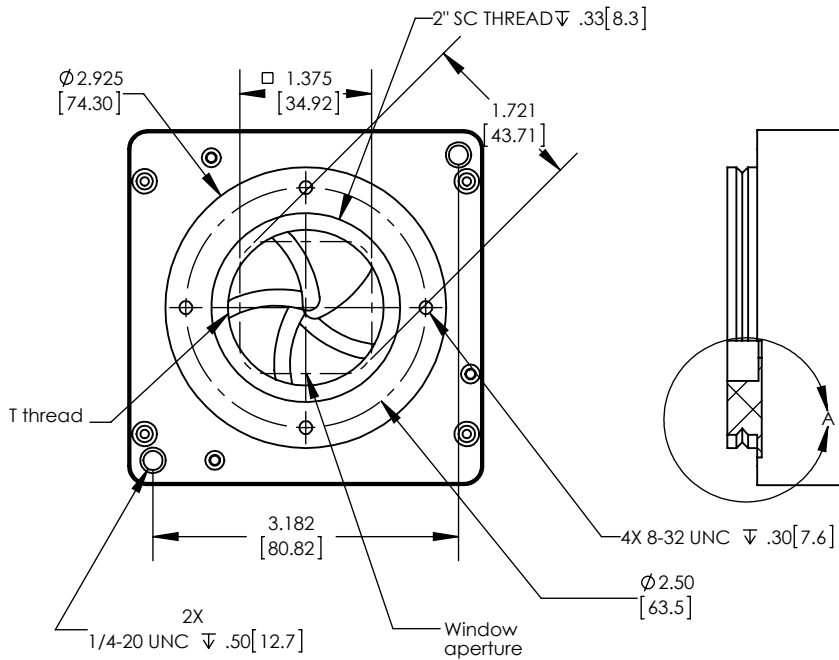
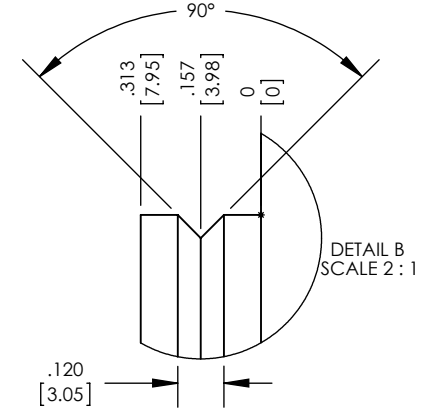
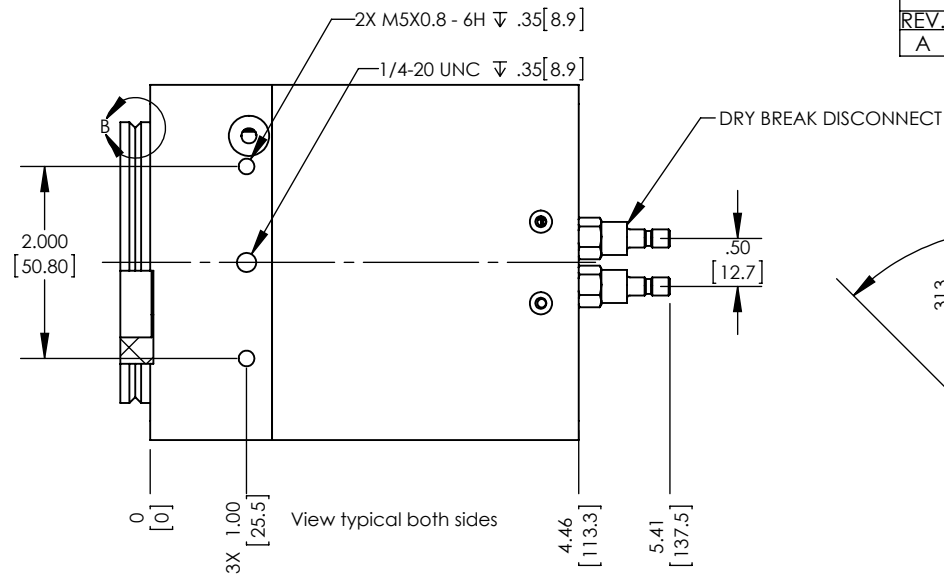
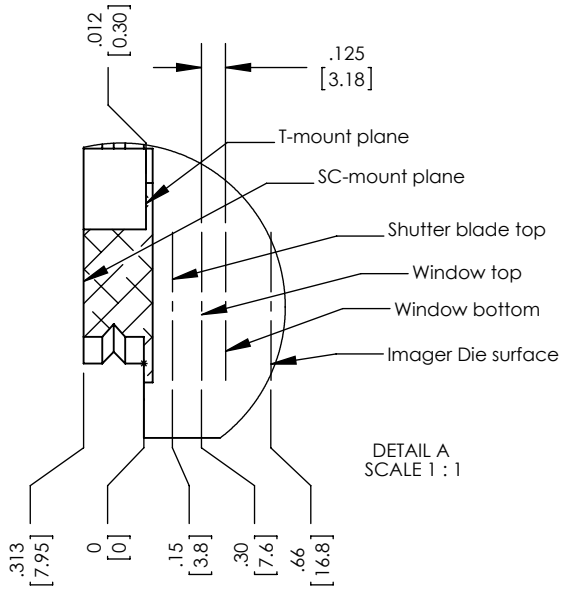

- NOTES:
- All dimensions are physical.
 - For optical distances:
 - Subtract 1mm for sealing window.
 - Subtract 0.3mm for CCD cover slip if present
 - Unless otherwise noted all dimensions are symmetrical about centerline.

M3VN-		NAME	DATE	Unless otherwise specified dimensions are in inches TOLERANCES: ∠ : ±1° X.XX ±.01 X.XXX ±.003 X.XXXX ±.0005	SIZE
DRAWN	REC		04/29/16		A
ENG.				WT:	
QUALITY				REV	
PROD.				A	
DO NOT SCALE DRAWING				INTERPRET GEOMETRIC TOLERANCING PER: ASME Y14.5	SCALE: 1:2 SHEET 1 OF 1