

Kepler CMOS Camera

KL400 FI

1.5 e- Noise RMS

The Kepler KL400 FI provides high sensitivity, ultra-low noise with high frame rates, all at a game-changing price to performance ratio. The front illuminated version does not have microlenses.

Technical Data

Sensor Type	Front Illuminated CMOS
Sensor	GPixel GSense400
Shutter Type	Rolling
Active Pixels	2048 x 2048
Pixel Size (microns)	11 x 11 μm
Imaging Area (Diagonal)	22.5 X 22.5 mm (31.8 mm)
Full Well Capacity	120000 electrons
(e-) Typical Readout Noise	1.5 e-
Dynamic Range	97.7 dB
Frame Rate	24 fps (Rolling HDR)
Cooling Method¹	Air and Liquid
Max. Cooling (Air)	45°C below ambient
Temperature Stability	0.1°C
Dark Current (typical)	0.015 eps at -20C
Interface	USB 3.0 (Optional QSFP ²)
Data Bit Depth	16 bit ³
Optional Shutter	45 mm
Optional Mounts	Nikon or Canon
Subarray Readout	Standard
External Trigger In/Out	Standard
SDK / Software	Kepler SDK (Open Source) /
Weight	3 lbs (1.3 kg)

¹ Liquid circulation connectors sold separately

² QSFP = Quad Small Form factor Pluggable: high speed fiber optic interface.

Support for KL400 in Q2 2020.

³ 16-bit data merged from two 12 bit converters



Also available with 45mm shutter

Absolute Quantum Efficiency

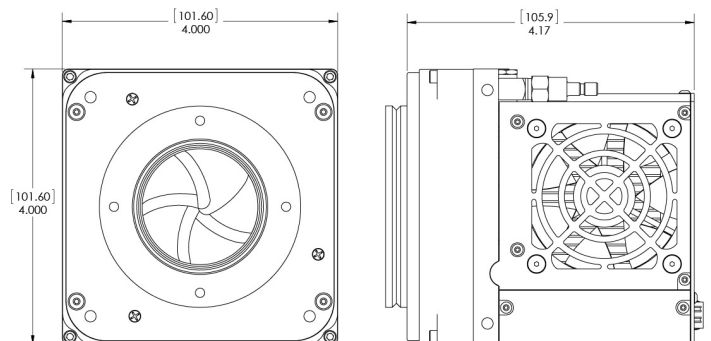
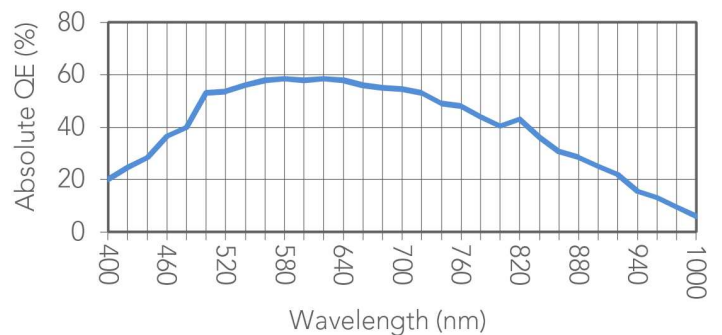

See www.flicamera.com for alternate configurations



MADE IN USA

Finger Lakes Instrumentation
www.flicamera.com
USA 585-624-3760